

SERIES 'EHM 3' VERTICAL PUMP

Refer to Bulletin P-309 and Parts List P-8790

The Series 'EHM 3' vertical pump is constructed of CPVC with choice of Viton or EPDM o-rings. All fasteners are stainless steel protected by o-rings for non-metallic solution contact. The cantilevered CPVC sleeved stainless steel shaft with compound impeller prevents solution from rising in the column, eliminating the need for bearings and conventional pump seals, allowing dry run capabilities for extended time without pump damage. Impeller design offers maximum pump output and the motors are sized for non-overloading at maximum flow conditions. Pump flow curves are based upon water. Increased motor horsepower will be necessary for pumping solutions with a specific gravity greater than 1.0 or reduced horsepower is permissible when pumping at higher discharge head. Trimmed impellers will reduce flow and discharge head.

Units are tested to confirm that the pump and motor functioned properly at time of shipment. Care should be taken to protect the pump components against unnecessary wear and physical abuse. Review parts list and maintain an emergency inventory of replacement items to assure that pump is returned to service with the least delay. Record model, serial and product code numbers for future reference. Specify numbers when ordering parts.

SAFETY PRECAUTIONS BEFORE STARTING PUMP

1. Read operating instructions and instructions supplied with chemicals to be used.
2. Refer to a chemical resistance data chart for compatibility of materials in pump with solution to be used.
3. Note temperature and pressure limitations.
4. Personnel operating pump should always wear suitable protective clothing: face mask or goggles, apron, gloves.
5. All piping must be supported and aligned independently.
6. Always close valves slowly to avoid hydraulic shock.
7. Ensure that all fittings and connections are properly tightened.
8.  Ground motor before connecting to electrical power supply. Failure to ground motor can cause severe or fatal electrical shock hazard. DO NOT ground to gas supply line.

BEFORE CHANGING APPLICATION OR PERFORMING MAINTENANCE

1. Wear protective clothing as described in Item 4 above.
2. Flush pump thoroughly with a neutralizing solution to prevent possible harm to personnel.
3. Shut off power to motor at disconnect switch.

INSTALLATION

The 3/4" NPT relief port located on the column must be above the solution level of the tank. Secure unit by drilling holes into the mounting plate and bolt assembly into a flat level position. Installing a valve on the discharge is recommended for regulating flow and pressure. Vertical discharge piping from the pump must be supported so that the pump column does not take the forces generated by the weight of the pipe and the liquid being pumped. Plastic piping has a high thermal expansion that should be considered when attaching discharge piping.

In-tank mounting (Figure A) is the most common method of installation. The pump and motor assembly mounted in-tank must be supported on all four sides of the mounting plate. A brace will be required, located across the center of the mounting plate next to the support column to prevent the mounting plate from warping.

The out-of-tank method (Figure B) does not consume tank space. However, it does require dual supports at the mounting plate, threaded or flanged connections in the tank wall, shut off valves to facilitate pump servicing, and the relief port must be plumbed back to the tank.

For safety and overload protection, installation of a motor starter and disconnect switch located near the unit are required. Verify motor is properly wired per incoming voltage. Rotation of motor must be correct. Incorrect rotation will cause an extreme reduction in flow rate, discharge head, and could cause the impeller motor fan end to unscrew from the shaft. A rotation arrow affixed to the motor indicates proper rotation, clockwise rotation from motor fan end.

CHECK ROTATION WITH PUMP OUT OF SOLUTION

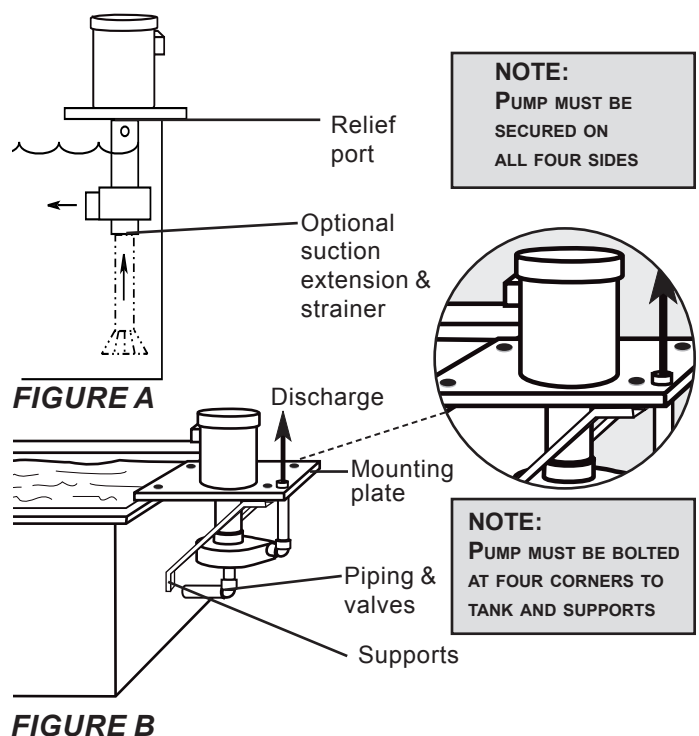

OPERATION

View the motor from the fan end and bump start (quick on off) the pump motor to verify correct rotation. Check rotation without liquid to the pump. This eliminates torque to the impeller, which will avoid the possibility of the impeller unscrewing from the shaft. Suction casing must be flooded for the pump to prime. A sticker (Figure C) affixed to the pump column indicates the minimum solution level before starting. Close discharge valve halfway and turn the pump on. Slowly open the discharge valve to the full open position. Listen for unusual noise, vibration, or other abnormal conditions which could affect pump performance. At maximum flow conditions, measure amperage on electrical supply lines, verifying amperage does not exceed rating on the motor nameplate. If using level controls, verify proper high and low level trip points are correct.

Flow rate and pressure can be adjusted by regulating the discharge valve. Do not close discharge valve completely. This is called "deadheading" the pump. Rapid temperature rise will occur causing considerable damage to the impeller inside the pump. If a valve was installed on the suction of the pump, it must be in the full open position during operation.

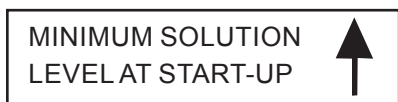
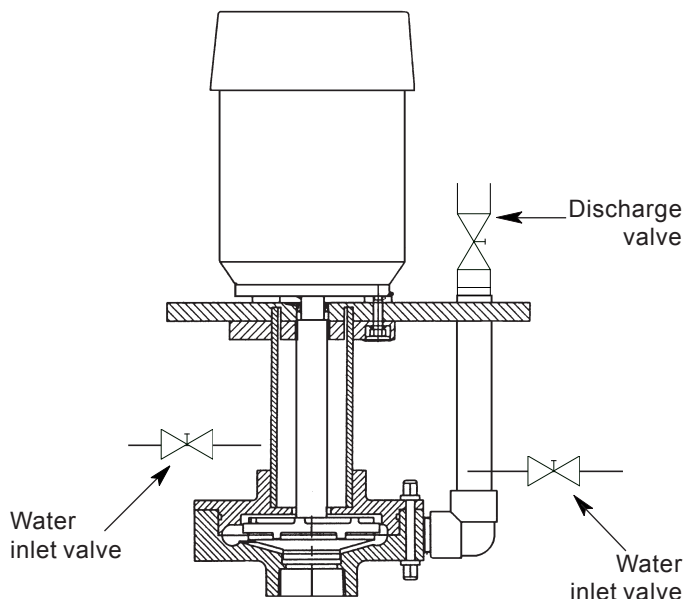

FIGURE C

PUMPING TIPS

1. When discharging overhead where there may be a considerable volume of liquid in the piping, it is recommended that a check valve be installed in the pump discharge. This will prevent unnecessary back siphoning which could flood the motor. Refer to TROUBLESHOOTING, #4.
2. Pumps provided with suction extensions must be started with liquid above the impeller. Note sticker on pump column Figure C.
3. Whenever two pumps are operating alternately in parallel flow, it is important to maintain separate discharge lines to the collection or process tank. If discharges are combined, solution discharged from the energized pump could flow into the de-energized pump. With no other place to go, the liquid will travel up the column of the de-energized pump and out between the mounting plate and motor, possibly causing premature failure of the motor. Furthermore, if a check valve is installed in each pump's discharge upstream of the joining of the lines to prevent the direct flow from one pump to the other, the weight of liquid above the check valve could prevent the pump from opening the check valve when the motor is energized. This will result in the improper pumping of solution, resulting in pump failure. If the installation includes combined discharges, problems can be avoided by using solenoid valves instead of check valves. The solenoid valves should be wired so that when pump **A** is operating, its valve is open and the valve on pump **B** is closed. Conversely, when pump **B** is operating, its valve must be open and the valve on pump **A** must be closed.

4. When pumping solutions that will solidify or crystallize, a water flush system will prolong the life of the internal pump components. A drilled and tapped hole would be required in the support column or on the discharge pipe as per Figure D. Close discharge valve and open water inlet to flush.



WATER FLUSH SYSTEM

FIGURE D

TROUBLESHOOTING

1. **Motor Stops -**
Check for correct voltage and wiring. See that starter has correct overload heaters. Take an amp-draw reading at operating conditions and compare to value on motor nameplate. If higher than nameplate value, check for friction-free rotation by turning motor fan with power disconnected. If high friction, bearings may need replacement.
2. **Pump does not deliver correct flow -**
Check suction strainer or pump inlet for debris. Compare required flow conditions of original specifications and pump curve. Check motor rotation. Check your data for determining required TDH.
3. **Pumps up column at start-up -**
Check for low liquid level at start-up. Refer to Figure A.
4. **Back flows up column at shut-down -**
Check for large volume of liquid in pump discharge line. If liquid is surging up the column, install a check valve in the discharge. Many different types of check valves exist and each has benefits and drawbacks which can adversely affect the pump. Test with water for proper operation.

PUMP SERVICE

TO REPLACE SUCTION CASING OR O-RING SEAL

1. Remove the (8) cap nuts that are holding the suction casing to the support casing plate. Remove casing o-ring and the (24) o-rings from the grooves of the cap nuts and suction casing. Replace casing o-ring into groove of suction casing and lubricate o-ring and support casing with a suitable rubber lubricant.
2. Place (8) o-rings into the grooves of the suction casing. Place o-ring into each of the (16) cap nut grooves. Line up holes of support casing plate to suction casing and fasten cap nut studs 18 ft-lbs.

TO REPLACE IMPELLER

1. Remove suction casing as previously described.
2. Remove motor fan cover and fan.
3. Grip end of motor shaft with vise grips.
4. Remove impeller cap nut stud from center of impeller.
5. Remove impeller by turning counterclockwise with a strap wrench.
6. Clean shaft and thread impeller onto shaft until it bottoms out. Replace cap nut stud and o-ring. Replace fan and fan cover. Insure fan does not rub.
7. Replace suction casing as described above.

TO REPLACE COLUMN, MOUNTING PLATE, VAPOR SEAL, AND MOTOR ADAPTER PLATE

1. Remove the suction casing and the impeller as described above.
2. Remove the (8) cap nuts that are holding the column to the mounting plate. Column and mounting plate can then slide off the shaft.
3. Remove the (4) flat head screws that are holding the motor adapter plate to the motor face.
4. Thread (4) 3/8-16x2-3/4" hex head bolts to motor adapter plate starting on side of plate without counter-sunk holes. Apply medium strength thread locker to engagement threads only.
5. Place (4) motor spacers onto motor face. Place motor adapter plate on top of motor spacers. Attach motor adapter plate to motor with the (4) flat head cap screws. Apply medium strength thread locker to screws. Make sure each screw goes through the motor spacer.
6. Place shaft vapor seal and (8) o-rings onto mounting plate. Slide mounting plate over pump shaft (vapor seal side first) locating the (8) hex head bolts. Place (8) o-rings on the other side of the mounting plate. Place column locating the (8) hex head bolts. Place o-ring into the (8) cap nuts and fasten evenly 18 ft-lbs.
7. Replace impeller and suction casing as described above.

TO REPLACE PUMP SHAFT

1. Remove suction casing, impeller, column, and mounting plate as described above.
2. Attach pipe wrench to fan end of motor shaft and use another pipe wrench on shaft. Remove pump shaft by turning counterclockwise.
3. Apply medium strength thread locker to motor shaft and insert pump drive shaft onto motor shaft. Attach pipe wrench to fan end of motor shaft and use another pipe wrench on shaft. Tighten shaft until shaft bottoms out on motor's rotor.
4. Check runout of shaft (eccentricity) using a dial indicator.
 - a. Put dial indicator on end of shaft.
 - b. Turn shaft to find high spot.
 - c. Using a 2 ft. pipe, press downward on the high spot of the shaft until run-out is within .005" Total Indicator Runout (TIR) maximum.
5. Reassemble mounting plate, column, impeller, and suction casing.

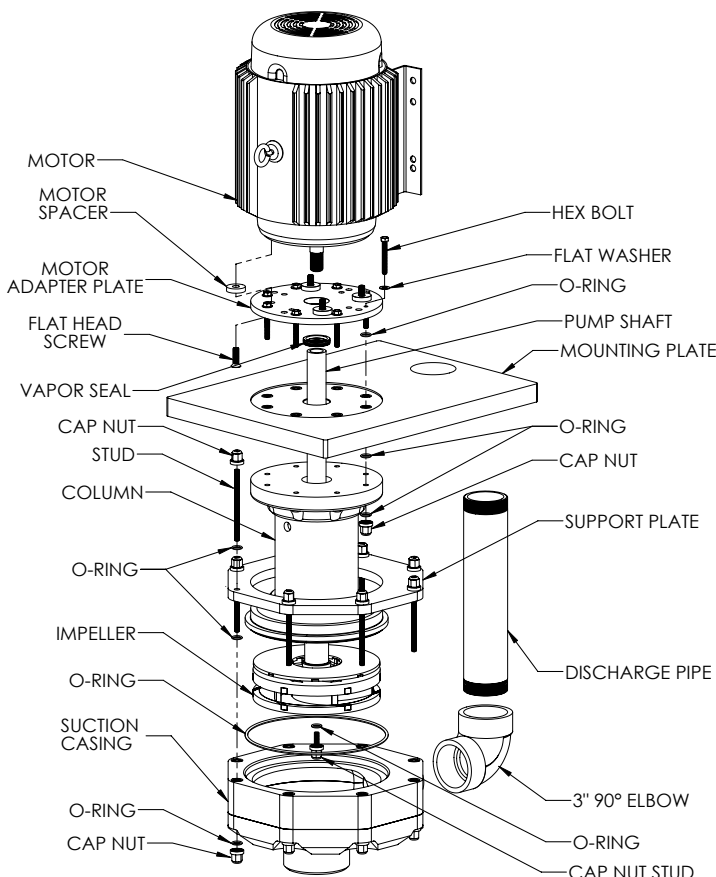

'EHM3' ASSEMBLY FIGURE
FIGURE E